

ADAPTER KIT

FORD 429-460 TO CHEVY PG AND TURBO WITH SFI FLEXPLATE 164 TEETH, INTERNAL BALANCE

Part # 915242

PARTS LIST:

- (1) #915120 Aluminum Adapter Plate
- (1) #915612 Crankshaft Adapter
- (1) #915700 SFI Flexplate
- (1) #950160 Hardware Package
 - 6 PCS #951390 3/8-16 x 1-3/4" Studs - **See note 4!**
 - 6 PCS #951480 7/16-20 x 1" Counterbore Screws
 - 6 PCS #951410 7/16-14 x 1" Flat Socket Head Screws
 - 6 PCS #952000 3/8-24 Hex Nuts
 - 6 PCS #953050 3/8" AN Flatwashers
 - 3 PCS #954130 1" OD x .325" Spacers
 - 2 PCS #958000 3/8" x 5/8" Dowel Pins

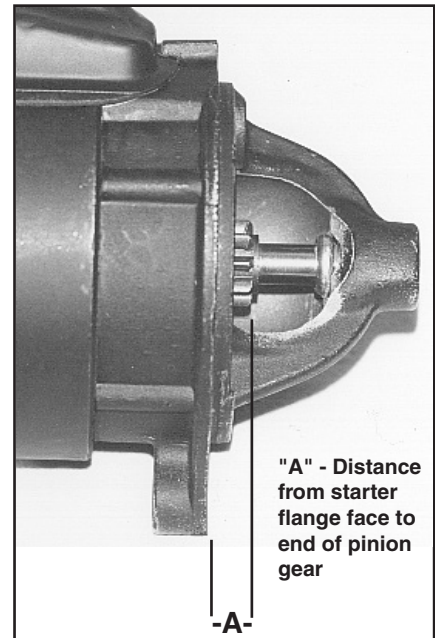
**NOTE:**

1. Do not use Loctite on screws which mount adapter plate to block.
2. Crankshaft adapter is placed on crankshaft, then the flexplate is bolted on.
3. The end clearance and engagement length of the starter pinion gear with the flexplate ring gear **MUST BE CHECKED** (See Figure 1). End clearance should be at least .050 inches and engagement length at least 2/3 of ring gear width. Listed below are nominal "A" distances for typical Ford Starters.
4. For Dedenbear cases, use 4 pieces #951390 (3/8-16 x 1-3/4 studs) and 2 pieces #951391 (3/8-16 x 5/8 studs). Use two longer studs on lower case bolt holes on the right and left.

ORIGINAL TRANSMISSIONC4, AOD
C6, E4OD
C6, E4OD**FORD STARTER**E4TF-11001-AA or Equiv.
D8AF-11001-AA or Equiv.
D1AF-11001-AA or Equiv.**"A" DISTANCE**.260 inches
.430 inches
.590 inches