

ADAPTER KIT

FORD 289 - 302 - 351C - 351W

TO CHEVY PG AND TURBO WITH SFI FLEXPATE

164 TEETH, INTERNAL BALANCE

Part # 915231

PARTS LIST:

- 1 (915110) Aluminum Adapter Plate
- 1 (915603) Crankshaft Adapter
- 1 (915704) SFI Flexplate
- 1 (950141) Hardware Package
 - 1 PC (951330) 3/8-16 x 1-1/4" Counterbore Screw
 - 6 PCS (951390) 3/8" x 1-3/4" Studs - **See note 4!**
 - 5 PCS (951410) 7/16-14 x 1" Flat Socket Head Screws
 - 6 PCS (951471) 7/16-20 x 1-1/4" Counterbore Screws
 - 6 PCS (952000) 3/8-24 Hex Nuts
 - 6 PCS (953050) 3/8" AN Flatwashers
 - 3 PCS (954120) 1" OD x 1/2" Spacers
 - 2 PCS (958000) 3/8" x 5/8" Dowel Pins

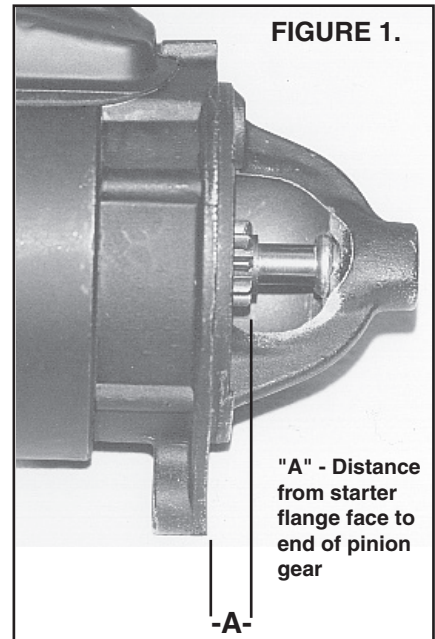
**NOTE:**

1. Do not use Loctite on screws which mount adapter plate to block.
2. Crankshaft adapter is placed on crankshaft, then the flexplate is bolted on.
3. The end clearance and engagement length of the starter pinion gear with the flexplate ring gear **MUST BE CHECKED** (See Figure 1). End clearance should be at least .050 inches and engagement length at least 2/3 of ring gear width. Listed below are nominal "A" distances for typical Ford Starters.
4. For Dedenbear cases, use 4 pieces #951390 (3/8 x 1 3/4 studs) and 2 pieces #951395 (3/8-16 x 3/4 and 3/8-24 x 1, 2 OAL studs). Use two longer studs on lower case bolt holes on the right and left.

ORIGINAL TRANSMISSION

C4, AOD
C6, E4OD
C6, E4OD

FORD STARTER

E4TF-11001-AA or Equiv.
D8AF-11001-AA or Equiv.
D1AF-11001-AA or Equiv.

"A" DISTANCE

.260 inches
.430 inches
.590 inches