

BILLET SERVO FOR C-4**Part # 645411**

Step 1 - Remove the four intermediate servo cover attaching bolts. Note the location of the transmission ID tag. As the bolts are removed, hold the cover in against spring pressure. (Figure 1.)

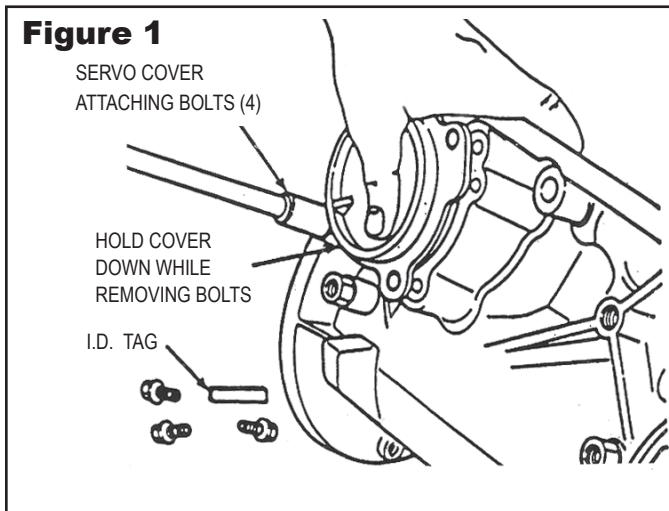

Step 2 - Remove the return spring from the servo piston rod. (Figure 2.)

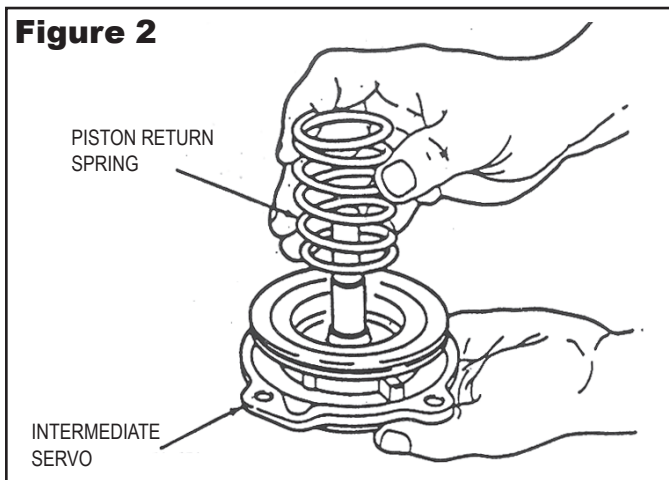
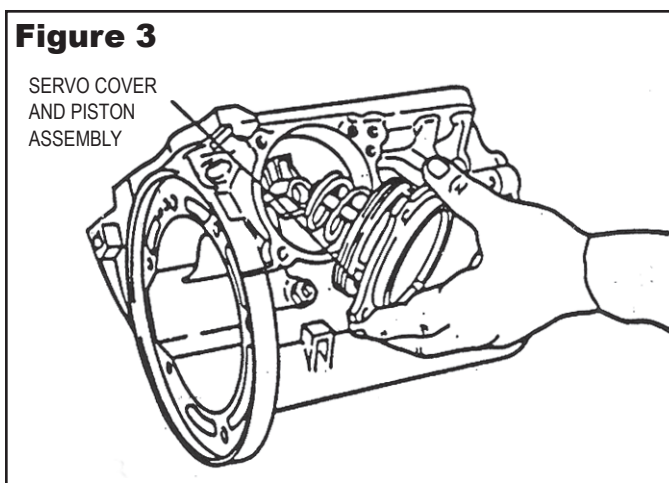

Step 3 - Remove the cover and servo piston as an assembly. Remove and discard the cover gasket. (Figure 3.)

Step 4 - Install 4 studs into transmission case with allen wrench.

If the transmission pan and valve body are still installed, you must align the slot on the servo pin with the band strut. Turn servo pin so that the slot is parallel to the transmission pan or horizontal to the vehicle. Failure to do this will result in no 2nd gear. The band strut may have been knocked out of position and will require pan and valve body removal to reinstall. This can be done with simple hand tools.

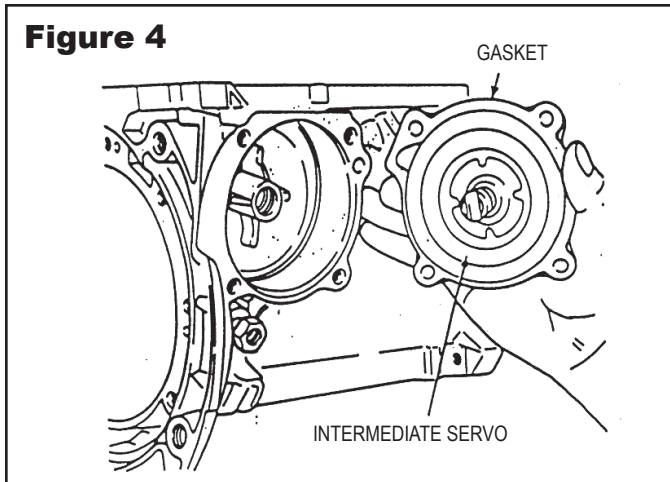

Step 5 - Position a new gasket on the low-intermediate servo cover.

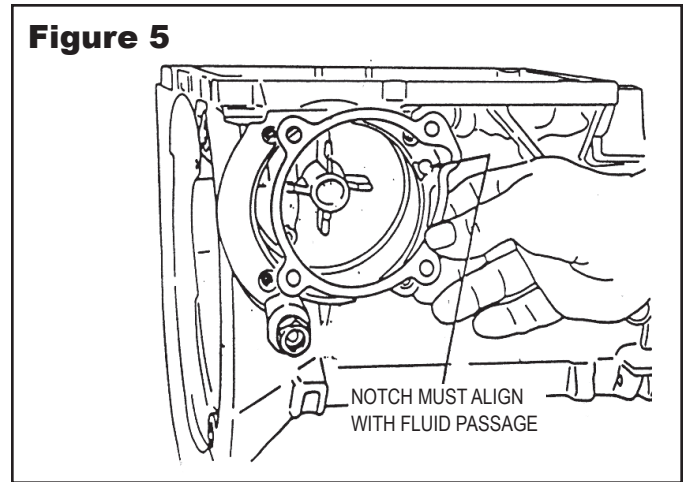

Step 6 - Align the gasket so that when the servo cover is installed, the notch in the gasket will align with the fluid port in the case. When the servo is installed, make sure the notch in the gasket aligns with fluid passage.

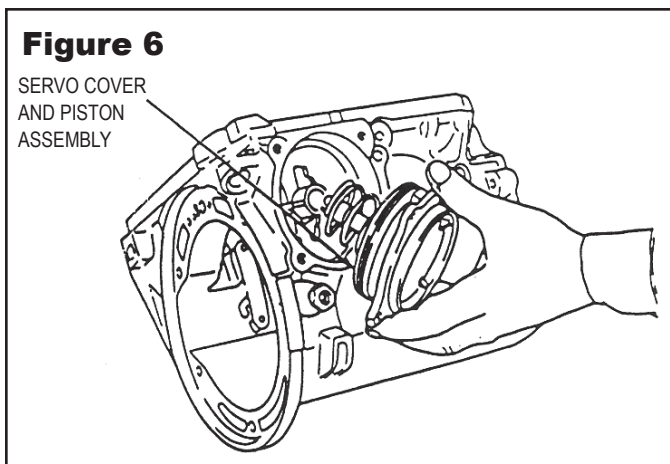

Step 7 - Install the low-intermediate servo cover, piston and return spring as an assembly.

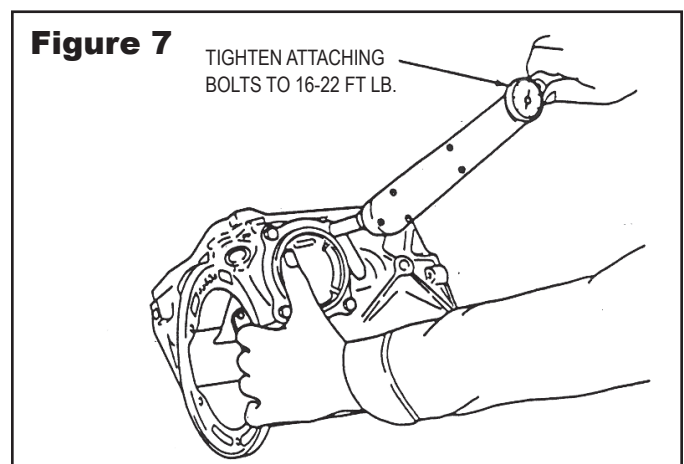

Step 8 - Install the four cover attaching bolts and tighten to 22-30Nm (16 - 22 ft lbs).

