

T-400 ALUMINUM DRUM & CENTER SUPPORT

Part #407056

Instructions

1. Install the supplied small case saver snap ring before the center support.
2. Install the supplied heavy duty center support.
3. Insert your OEM beveled snap ring with the bevel facing up (toward the front of the transmission).
4. Install the supplied thick steel first and then alternate clutches and steels.
5. Place supplied pressre plate .
6. Install the heavy duty snap ring so the opening is between the 2 lug opening on the driver's side of the case.
7. Install the supplied heavy duty aluminum drum (fully loaded with clutches, steels, piston and snap ring).
8. Complete the rest of the build in the usual manner and verify correct endplay.
9. Use an OEM plastic or bronze thrust washer between the direct clutch drum and the forward clutch hub.

Forward clutch drum side

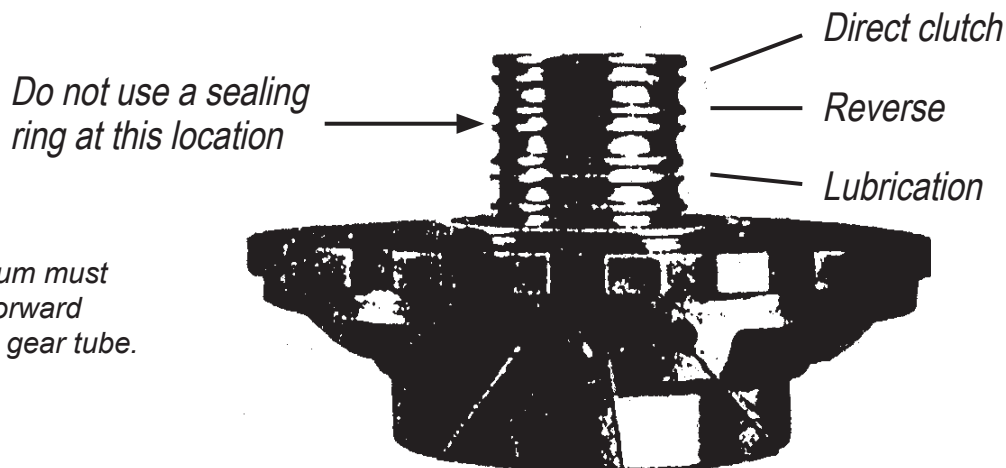
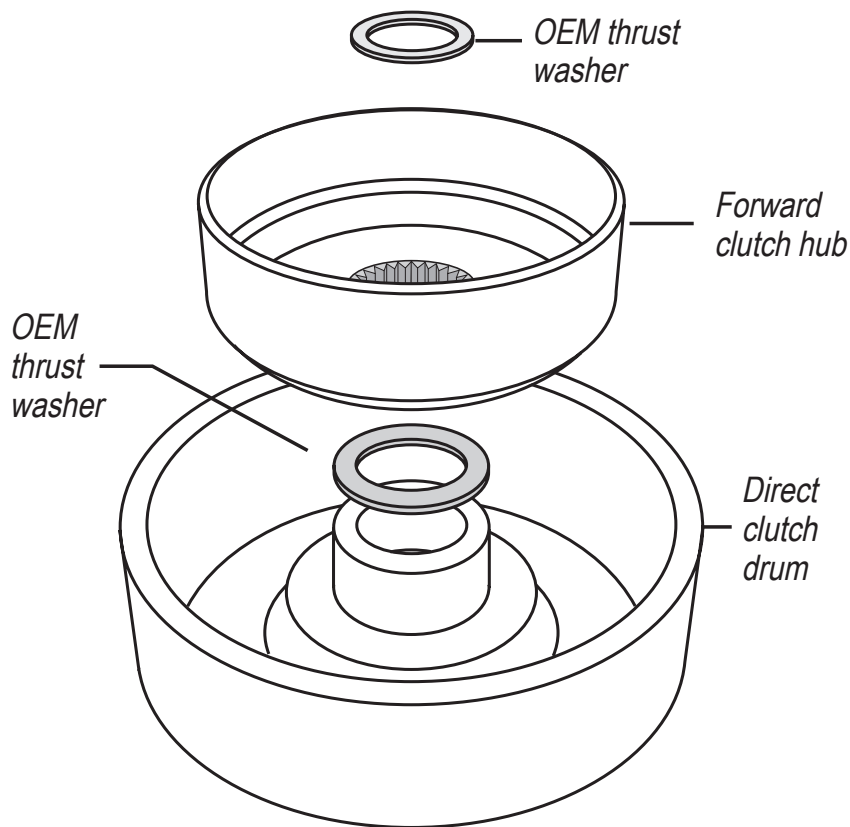

Note! The direct drum must float between the forward clutch hub and sun gear tube.