

T-400 BILLET ALUMINUM TRANSBRAKE

Part # 403091

P-R-N-1-2-3

PACKING LIST

- | | |
|---|--|
| <input type="checkbox"/> (1) Billet Aluminum Valve Body Assy. | <input type="checkbox"/> (1) 1/2" Nylon Ball |
| <input type="checkbox"/> (1) Separator Plate | <input type="checkbox"/> (6) 5/16-18 1" Button Head Bolts |
| <input type="checkbox"/> (2) Valve Body Gaskets (#403222) | <input type="checkbox"/> (2) 5/16-18 1½" Button Head Bolts |
| <input type="checkbox"/> (1) Solenoid with Adapter | <input type="checkbox"/> (3) 1/4-20 1" Hex Head Bolts |
| <input type="checkbox"/> (1) Modulator Plug | <input type="checkbox"/> (1) 5/16-18 1¾" Button Head Bolt |
| <input type="checkbox"/> (1) Electrical Connector | <input type="checkbox"/> (1) Instruction Sheet |
| <input type="checkbox"/> (16) HD Direct Drum Springs | |

Packed by: _____



Accidental transbrake engagement poses a serious safety risk! You must have safety electronics in place to safeguard against accidental engagement of the transbrake solenoid when not intended.

ATI can assume no responsibility for workmanship or driving procedures that are out of our control. Read all instructions carefully. Failure to comply may cause extreme damage, possible explosion of the transmission and/or injury or death to the driver!

For your protection, always use a transmission shield, blanket or SFI case!

**** DO NOT SHUT OFF THE ENGINE WHILE IN THE TRAPS! ****

***** Can use Reverse or Neutral for Back Up *****



Note: For units running more than 250 psi, you MUST have a minimum of 14 volts at the starting line with all necessary accessories operating.

All modifications are essential. Follow as shown!

STEP 1 - High Drum

Preparation of the high clutch drum is extremely important. Removal of the piston is necessary. A 1/16" inch (.063") bleed hole is drilled through the drum in the area behind the piston. It is best to drill from the inside out placing the hole as close to the outer sealing portion as possible (big lip seal). The drill may be held at an angle for more drilling room (Figure 1).

Reinstall the piston in the drum using only two (2) lip seals, the outer and the inner. **Do not use the center seal!**

Discard the 16 original piston springs and replace with the special springs provided with this kit.

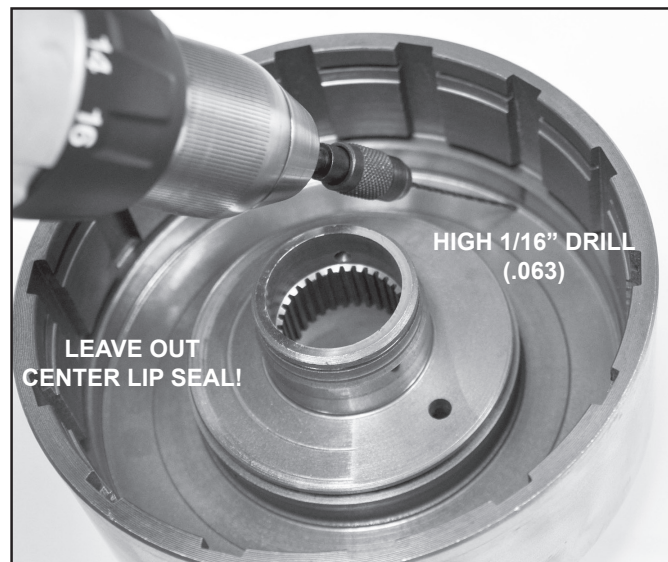

Figure 1

STEP 2 - Transbrake Electrical Connection

This connection is activated by applying 12 (or 16) volts into the spade connector where the kickdown lever used to be in the OEM case. An SFI case will require 940340 Pass Thru Connector. Use minimum 16 gauge wire and a 20 amp fuse. Solenoid pulls about 6 to 8 Amps.

STEP 3 - Use a Stock 400 Modulator valve

Inspect the valve. It cannot be modified or ground in any way!

Case Preparation: This valve body requires no case modifications.

Intermediate Servo: Leave out the intermediate servo, servo spring, parts and intermediate band.

Valve Body Gaskets: Run a flat file or a whetstone over the case to remove any high spots that might cause a crossover leak and install supplied gaskets.

Manual Valve: Clean your stock manual valve, dip it in clean transmission fluid and install in your ATI valve body.

Rear Servo: The rear servo is installed in the normal manner. The two (2) accumulator rings may be removed if desired. Use stock springs and parts.

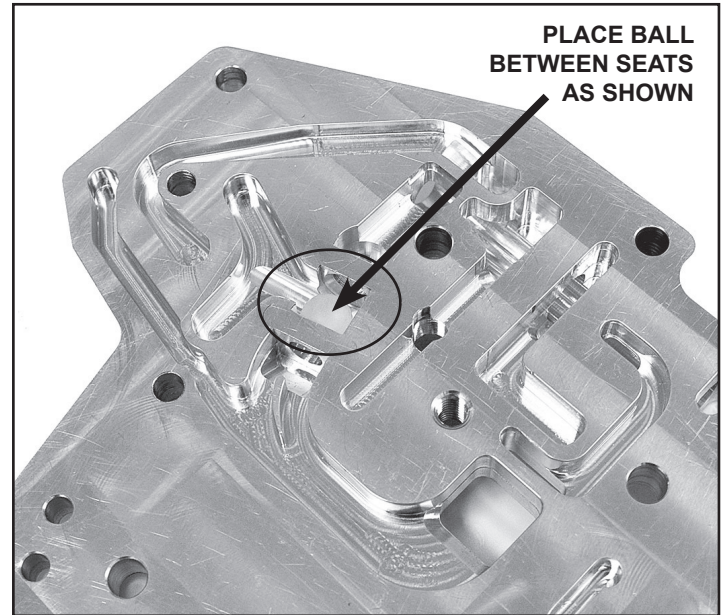

(Figure 2)

CENTER SUPPORT - Installation of Teflon rings

(ATI part # 405471 HD Center Support shown)

Step 1 - Fill the groove with assembly lube. (Figure 3)

Step 2 - Hand shape rings as round as possible.

Step 3 - Fit a ring into the groove.

Step 4 - Use the same procedure for the front pump.

The assembly lube will hold the rings in place during assembly, however they will not seal until the transmission has been run, don't expect them to pass an air check.

Note! If using an OEM Center Support, you MUST leave the second ring off!

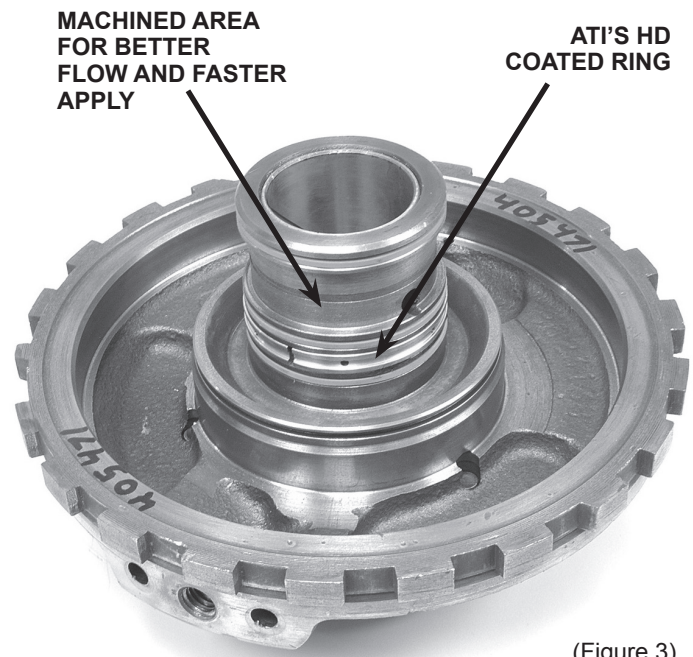

(Figure 3)