

# POWERGLIDE SHORTY EXTENSION HOUSING WITH SPHERICAL BEARING

Part # 207850

**Case must be threaded for a vacuum modulator!**

*Prior to installing any parts, please read all the instructions and select only those that pertain to your application. If your case is a 1962 - 1966 and had a rear pump assembly in it, a new reverse feed hole must be drilled. Do not drill this hole with the reverse piston still installed in the case!*

REAR VIEW OF CASE

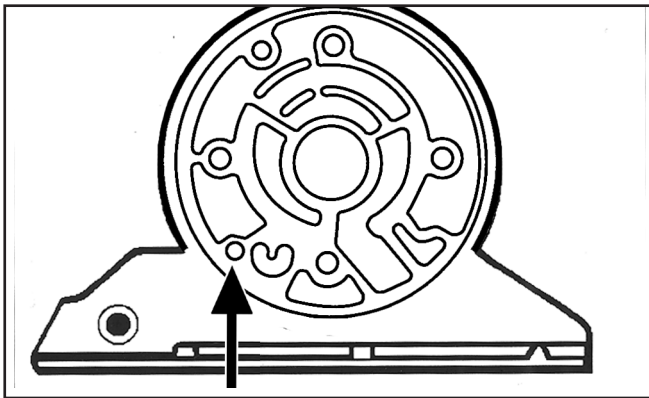

REVERSE FEED HOLE "A"

BOTTOM VIEW OF CASE

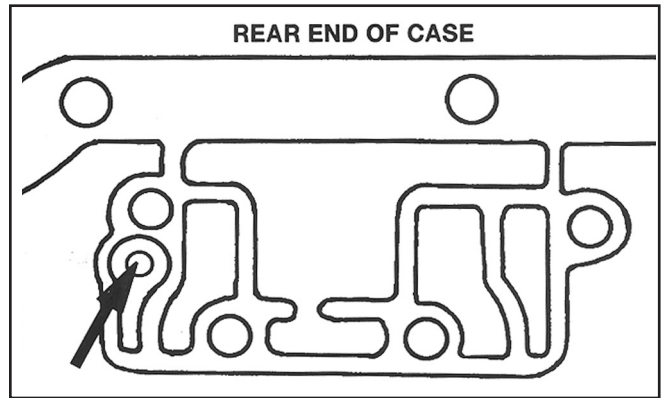

REVERSE FEED HOLE "A"

(Drill to intersect with - but not past - hole "A")

Select one of the following:

- A) **Manual Valve Body** - Drill 1/8" through hole A and 1/8" intersecting hole B where indicated in the above illustrations. Holes exist in 1967 and newer cases.
- B) **Internal Solenoid Transbrake** - Drill 5/16" through hole A and 5/16" intersecting hole B where indicated in the above illustrations. Both holes are required for all model cases.
- C) **External Solenoid Transbrake** - Drill 13/32" through hole A and 13/32" intersecting hole B where indicated in the above illustrations. Both holes are required for all model cases.

## INSTALLATION

---

1. Remove the 1/8" Set Screw Access Plug to allow an allen wrench to access the two set screws on the bearing collar.
2. Install the coupler to bottom on the transmission case, then back it out 1/8" minimum.
3. Rotate the coupler until the two set screws are visible through the inspection hole.
4. Tighten both set screws to lock the Spherical Bearing inner race to the coupler.
5. Install the plug with sealant

