

POWERGLIDE ALUMINUM CLUTCH DRUM

Part # 207020 - 205650 - 205651 - 205660

- **High RPM modification!**

Engine RPM in excess of 8,000 RPM will require an additional 3/16 hole drilled directly opposite the existing hole in the front pump. Drill hole, break sharp edges and remove burrs.

- As of January 2015, all ATI pumps have extra lube holes added.
- All aluminum drums now have a steel sleeve installed for teflon ring use and a Teflon coated bushing is installed.

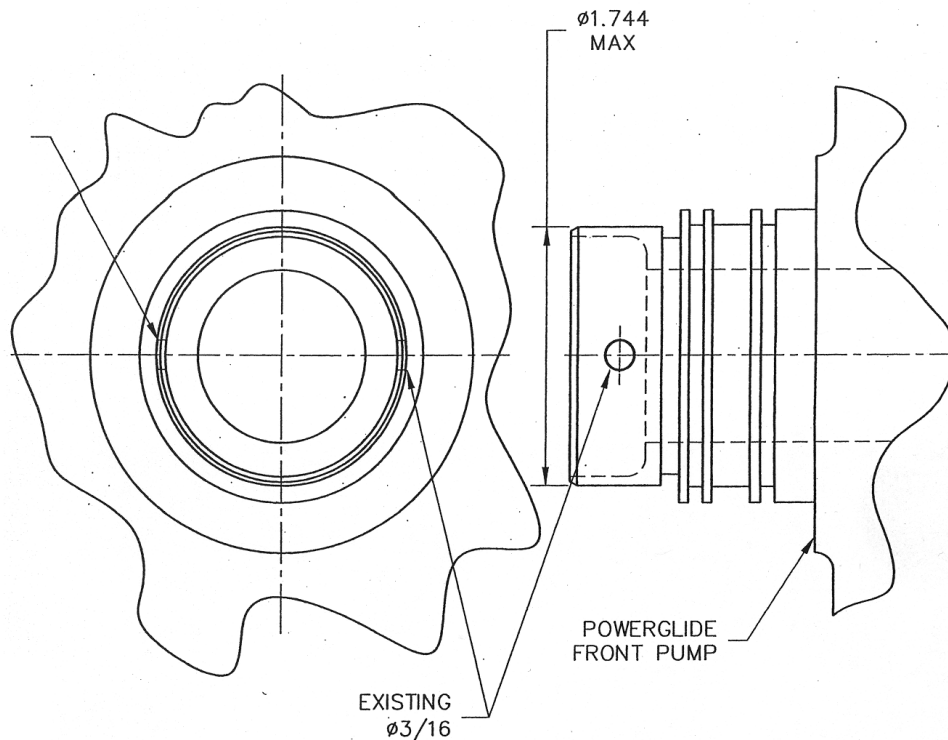

1. Soak Band in transmission fluid for one (1) hour prior to installation.
2. Tighten band to 80 inch/lbs, then back out 4½ turns. Check after second pass and readjust if needed.
3. Acceptable transmission end play: .025 – .040.